

6	5	4	3	2	1
NOTES:			SYMBOL	REVISION RECORD	DATE
Vial sensitivity: 32 minutes per 2mm bubble movement, Welded end caps			Liu	Drawn	2005-02-10

D

D

C

C

B

B

A

A

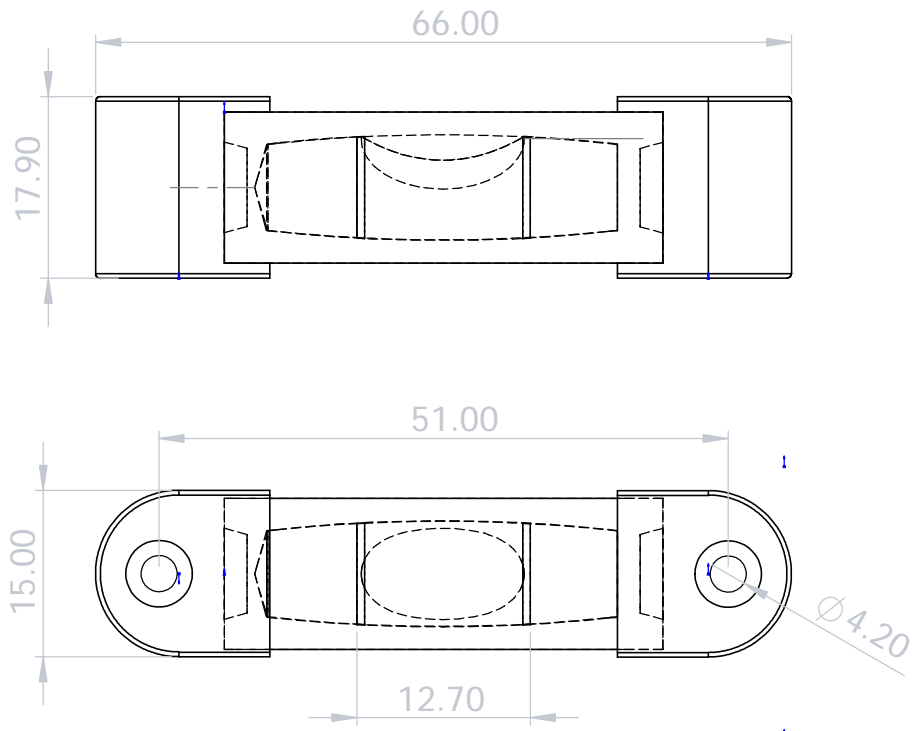

A	 L.V Level Co.,Ltd www.level-tool.com sail@level-tool.com	Unless Otherwise Specified:Units: mm Tolerances: XX. ± 1.0 XX.X ± 0.25 XX.XX ± 0.1	MATERIAL: PMMA	DRAWN BY:	DATE: 2005-02-10	A
	768#,Nanhai Road,Nantong,Jiangsu,China	TITLE: Low cost screw on level PSOL-SF35	SCALE: 2:1	liu	DRAWING NUMBER PSOL-SF35	1

6

5

4

3

2

1