

**NOTES:**

2degree for 5 mm ball movement  
bubble size: 20mm, AT 20°C

**SYMBOL**

Liu

**REVISION RECORD**

Drawn

**DATE**

2009-5-31

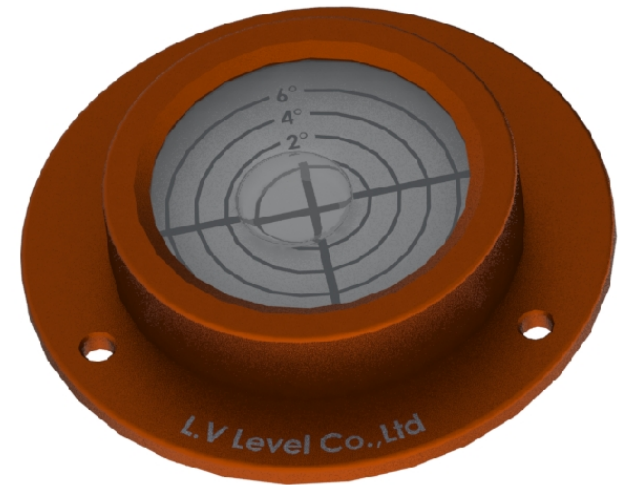
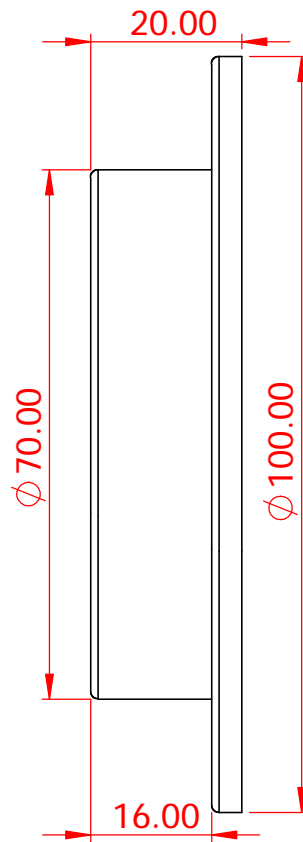
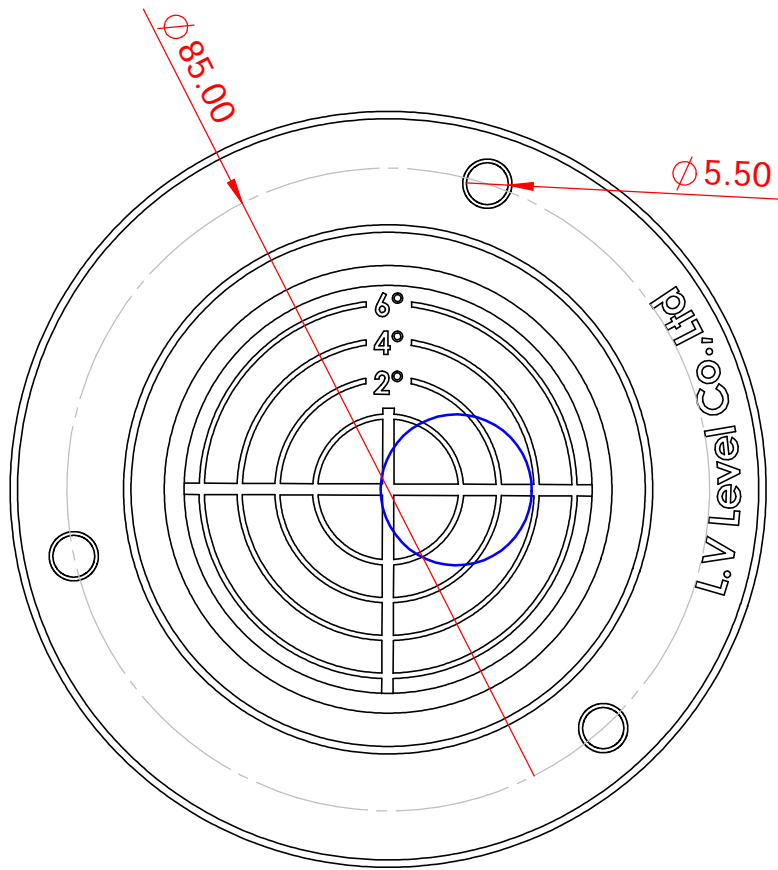

**L.V Level Co.,Ltd**

[www.level-tool.com](http://www.level-tool.com)  
[sail@level-tool.com](mailto:sail@level-tool.com)

Unless Otherwise Specified:Units: mm  
Tolerances: XX. ± 1.0 | XX.X ± 0.25 | XX.XX ± 0.1

**TITLE:** Circular Inclinometer Levels

**MATERIAL:**  
Vial: Ceramics  
Housing: Aluminium

**SCALE:** 1:1

**DRAWN BY:**

liu

**DATE:** 2009-5-31

**DRAWING NUMBER**

CIL5229-3