

NOTES:

Bubble Size: $11.8 \pm 0.3 \text{mm}$, 20°C
 Sensitivity : $4'/2\text{mm}$
 Line Thickness: 0.30mm
 Accuracy: Levelled to Surface A within $1.4'$

SYMBOL

REVISION RECORD

DATE

Liu

Drawn

2007-7-10

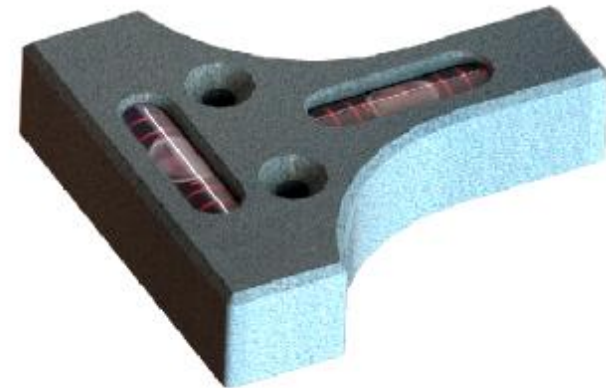
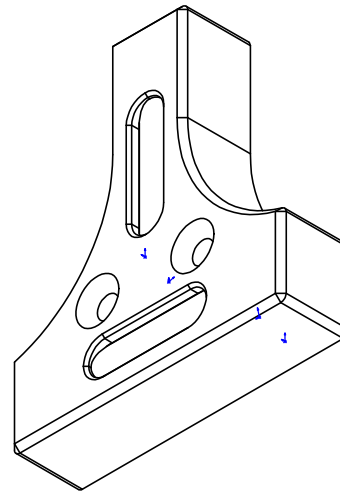
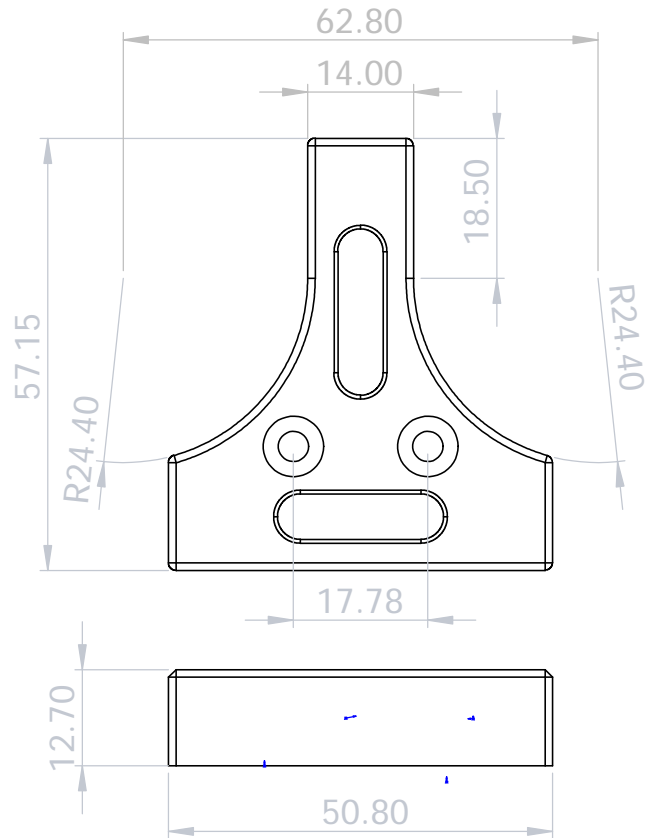

 **L.V Level Co.,Ltd**
www.level-tool.com
sail@level-tool.com

Unless Otherwise Specified: Units: mm
 Tolerances: XX. ± 1.0 | XX.X ± 0.25 | XX.XX ± 0.1

MATERIAL:
 Vial: Glass
 Housing: Aluminum Plate
 liu

DRAWN BY:

DATE: 2007-7-10

DRAWING NUMBER

768#,Nanhai Road,Nantong,Jiangsu,China

TITLE: Two axis level assembly

SCALE: 1:1

2AL-T20